

# APX 4 COAXIAL

- 1 Concentric Coaxial Tweeter: tweeter is mounted within the woofer with one single point of emission providing consistent phase response, with an accurate recreation of the sound stage comparable to that of a component system.
- 2 Tweeter features an acoustic lens specifically designed to ensure an extremely linear frequency response, even in off-axis placement, typical of in-door installations.
- 3 32 mm pure copper voice coil, for high power handling and outstanding low frequency control
- 4 Overall mounting depth optimized for OEM Integration thanks to the concentric tweeter and the low profile basket
- 5 Water-repellent treated paper cone, featuring a profile developed with FEM (Finite Element Method) simulation technology and optimized with the Klippel Scan Vibrometer.
- 6 TPU (Thermoplastic Polyurethane) surround, featuring the exclusive shallow "Triple Wave" profile, for maximum excursion linearity.
- 7 Compact basket, protected by abrasion-resistant and scratch-proof coating, the motor affixed with damping epoxy adhesive.
- 8 High current fast-on terminal with double contact on positive and negative poles for high flexibility and quick connection. The terminal features a temperature resistant plastic cover, protecting it against accidental short circuits.
- 9 Developed with the KLIPPEL suite.

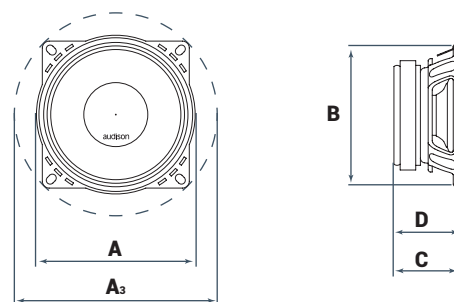
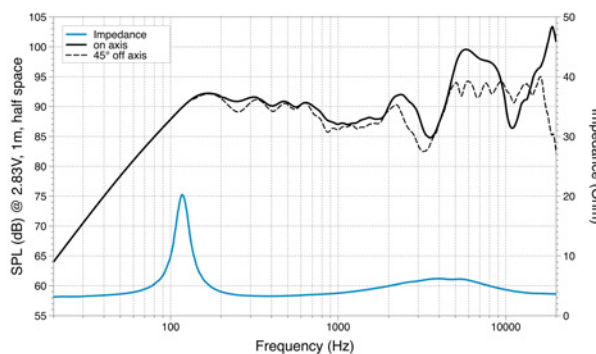

A	A <sub>3</sub>	B	C	D	
102	130	93	43	41	mm
4	5.12	3.66	1.7	1.62	in.

## TECHNICAL SPECIFICATIONS

Component		2-way Coaxial
Size	mm (in.)	Woofer 100 (4) Tweeter 24 (0.9)
Power Handling	W peak	120
	W continuous	40
Impedance	Ω	4
Frequency Response	Hz	80 ÷ 23k
Magnet size	mm	75 x 40 x 10
D x h	(in.)	(2.95 x 1.57 x 0.4)
Weight of one speaker	kg (lb)	0,49 (1.08)
Woofer Voice Coil Ø	mm (in.)	32 (1.26)
Tweeter Voice Coil Ø	mm (in.)	15 (0.6)

## ELECTRO-ACOUSTIC PARAMETERS

D	mm	85
Xmax	mm	±1,3
Re	Ω	3,1
Fs	Hz	125
Le	mH	0,04
Vas	l	1,5
Mms	g	5,3
Cms	mm/N	0,3
BL	T·m	3,2
Qts		1
Qes		1,2
Qms		8
Spl	dB	91